



**INSTALLATION AND
MAINTENANCE
MANUAL**

Code	MAN-0008e
Revision #	02
Last revision date	12/03/2025

PAGE .1 of 37

PROPELLER WITH HYDRAULIC SYSTEM

**IN-FLIGHT VARIABLE PITCH PROPELLER
BY HYDRAULIC SYSTEM**

**TYPE : VPH3 / VPH6
WITH BLADES LOCKING PLATE SYSTEM
(HUB TYPE C)**

**INSTALLATION
AND MAINTENANCE
MANUAL**

 fp propeller AIRCRAFT AND UAV PROPELLERS	INSTALLATION AND MAINTENANCE MANUAL	Code	MAN-0008e
		Revision #	02
		Last revision date	12/03/2025
PAGE .2 of 37	PROPELLER WITH HYDRAULIC SYSTEM		

N.B. THIS PROPELLER IS WITHOUT CERTIFICATION. ANY RESPONSABILITY IN THE USE OF THIS PROPELLER IS IN CHARGE TO THE USER

IMPORTANT WARNINGS

- The variable pitch propeller is a "machine" performing its operations during the flight of the aircraft. This is the reason why the pilot must know in deepness how it works.
- Wrong commands to the pitch of the propeller can greatly reduce the flight safety.
- It is strongly recommended that pilot asks for authorized personnel only, for installation, maintenance and operating instructions.
- The propeller is a component of the aircraft subjected to great stress and to constant overall vibratory system.
- Our propellers are made by selected and certified materials, according to widely proven techniques in order to ensure high safety factors of each component.

Unfortunately, we do not have useful tools to indefinitely ensure the propeller structure and its running in operational conditions so severe, and, in particular, in absence of adequate periodic maintenance.

- Therefore, it is pilot's responsibility to thoroughly check the propeller before each flight and carry out all checks of operation and maintenance reported in this manual
- In particular, these checks allow the pilot to highlight harmless problems (signs, cracks, surface etc ..) before they become serious problems. Any abnormal behavior during use, along with any "signs" should be investigated in a preventative way, in order to act properly and promptly.

Revision control

Rev.	Change	Approved	Date
00	Initial release	FP	05/05/2021
01	Added Ch.3 - Ch.11 - Annex A	FP	24/02/2022
02	Change grease type	FP	12/03/2025

Table of Contents

1. SYMBOLS USED	5
2. BEFORE INSTALLATION	6
3. PHYSICAL DESCRIPTION	7
4. PROPELLER INSTALLATION.....	9
5. SPINNER INSTALLATION	19
6. PROPELLER BALANCING:	21
7. END STOP ADJUSTMENT	22
7.1 Adjustment of the mechanical minimum end-run.....	22
7.2 Adjusting the mechanical maximum end run.	24
8. MAINTENANCE OPERATION	25
8.1 Pre-flight checks:	25
8.2 HUB AND METAL SHANKS SCHEDULED MAINTENANCE.....	27
8.3 BLADES SCHEDULED MAINTENANCE.....	30
9. SPECIAL CHECKS.....	31
10. PARTS TIME BETWEEN OVERHAUL (TBO).....	31
11. IDENTIFICATION	32
12. ANNEX A.....	33

 fp propeller AIRCRAFT AND UAV PROPELLERS	INSTALLATION AND MAINTENANCE MANUAL	Code	MAN-0008e
		Revision #	02
		Last revision date	12/03/2025
PAGE .5 of 37	PROPELLER WITH HYDRAULIC SYSTEM		

1. SYMBOLS USED

This Manual uses the following symbols to emphasize particular information. This information is important and must be observed.

 **WARNING** Identifies an instruction which, if not followed, may cause serious injury including the possibility of death.

 **CAUTION** Identifies an instruction which, if not followed, may cause minor or moderate injury.

 **NOTICE** Denotes an instruction which, if not followed, may severely damage the engine or other components.

 fp propeller AIRCRAFT AND UAV PROPELLERS	INSTALLATION AND MAINTENANCE MANUAL	Code	MAN-0008e
		Revision #	02
		Last revision date	12/03/2025
PAGE .6 of 37	PROPELLER WITH HYDRAULIC SYSTEM		

2. BEFORE INSTALLATION



CAUTION In order to avoid problems concerning the incorrect installation of your new propeller and therefore its correct operation, we strongly advise you to carry out the following checks on your aircraft:

- Check the correct carburation.
- Check the correct balance of the carburettors.
- Check the integrity of the propeller gearbox.
- Check the calibration of the springs in Rotax engines and that they are exclusively equipped with anti-tear clutch.
- Check the engine intake system if is not partially obstructed and if the maximum supply pressure can be achieved when the full throttle is entered.
- Carefully clean the contact surfaces of the motor flange with a light solvent, making sure that the flange itself has not been damaged by previous impacts of propellers on the ground.
- Check by authorized workshop that the run-out from the centering nose and the run- axial out are not out of tolerance as per the data of the engine manufacturer. In addition, make sure there is no deformation or surface scratching that could compromise the perfect coupling between the motor flange and the propeller flange.
- Carefully check the motor flange even on new engines.
- Propeller clearance: propeller installation must be compliant with: EASA CS22-SUB E – (CS 22.925)

3. PHYSICAL DESCRIPTION

The hub of the propeller is a single high strength component, manufactured from solid billet material.

Other components within the propeller are machined from a variety of engineering materials.

In essence, the pitch control mechanism is based on the position control of the hydraulic piston, which is integral with the cam follower block which controls the pitch.

The engine oil pressure is regulated by the governor and acts on the lower face of the piston. The force of a spring acts on the upper face of the piston, operating in a state of compression.

The axial motion of the piston stops at the point where the oil pressure and the spring force are equal to each other.

To change the pitch corresponding to this piston position it is necessary to change (decrease or increase) the oil pressure.

The pitch variation is therefore obtained by varying the oil pressure generated by the governor.

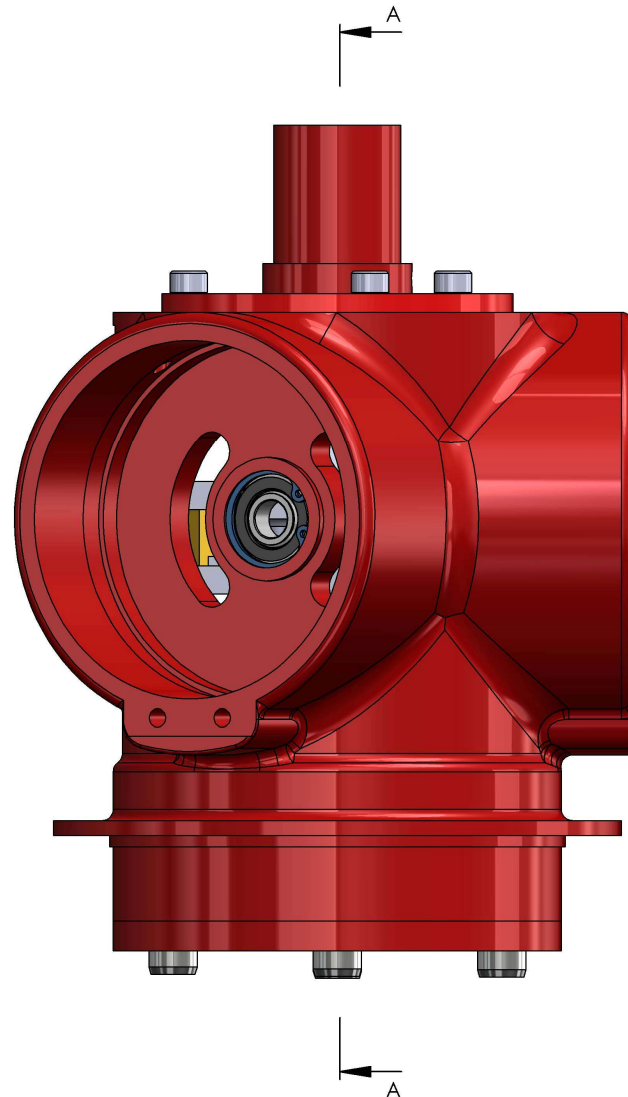

Fig. 3.1

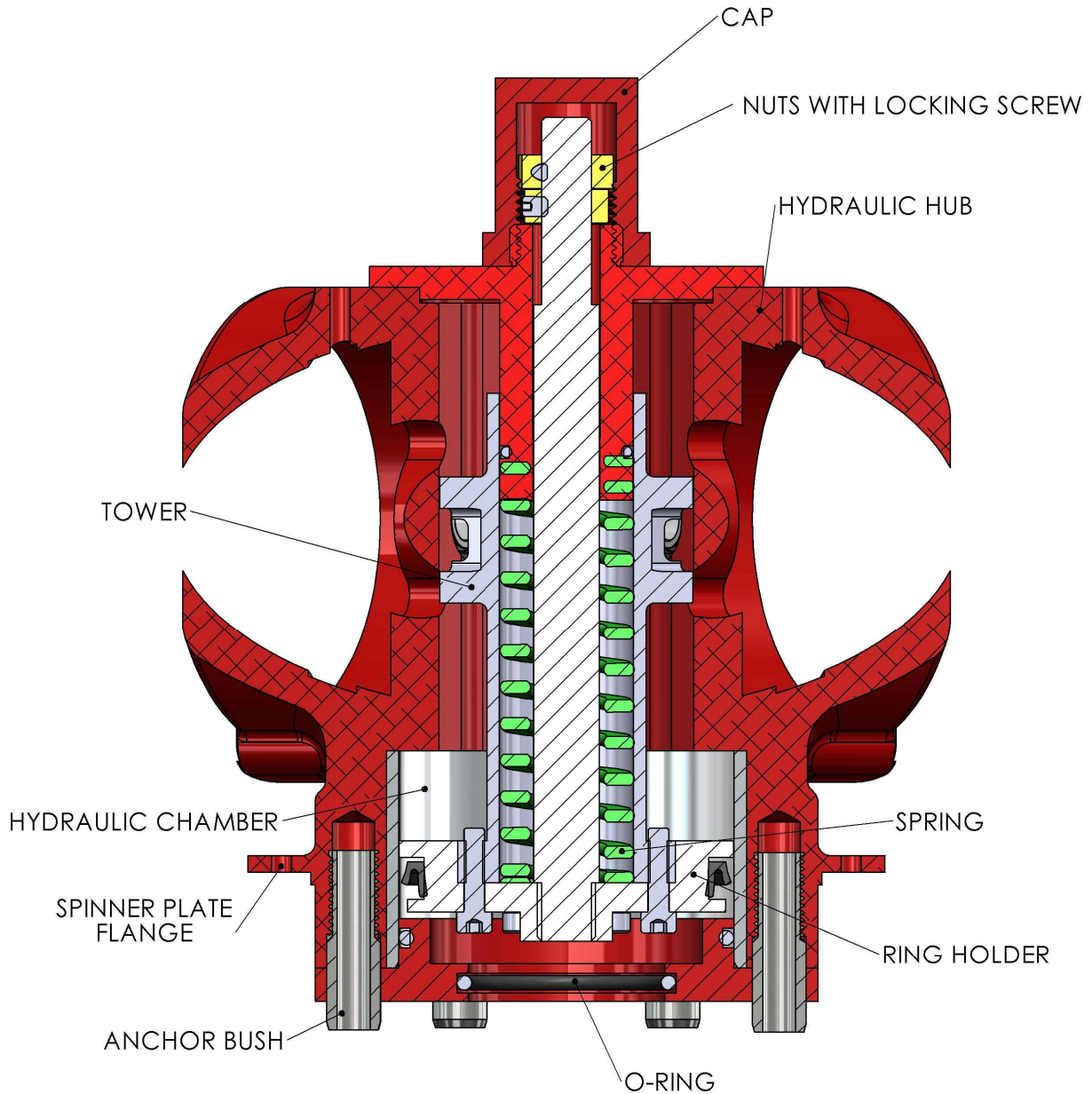



Fig. 3.2 AA SECTION

 fp propeller AIRCRAFT AND UAV PROPELLERS	INSTALLATION AND MAINTENANCE MANUAL	Code	MAN-0008e
		Revision #	02
		Last revision date	12/03/2025
PAGE .9 of 37	PROPELLER WITH HYDRAULIC SYSTEM		

4. PROPELLER INSTALLATION

WARNING

The installation technique described here is related to the Rotax engine with reduction gear box for Hydraulic propeller.

For other engines without gearbox, contact the manufacturer.

NOTICE

a) Insert the studs in the bushes, by applying strong threadlocker (e.g. type AREXON SYSTEM 52A70 – LOCTITE 290)



Fig. 4.1

Screw until **20 mm of visible thread remains**



Fig. 4.2

NOTICE

In the case of installation with spacer, the projection from the stud to the spacer must be 29mm
In the case of installation with the Carbon deluxe model FP-propeller spinner, before proceeding to the next step, go to chapter 5 (Spinner installation).

b) Insert the hub base in the flange



Fig. 4.3

 fp propeller AIRCRAFT AND UAV PROPELLERS	INSTALLATION AND MAINTENANCE MANUAL	Code	MAN-0008e
		Revision #	02
		Last revision date	12/03/2025
PAGE .11 of 37	PROPELLER WITH HYDRAULIC SYSTEM		

c) Insert the special washers.

⚠ CAUTION Be sure to insert the washers as shown in the figures

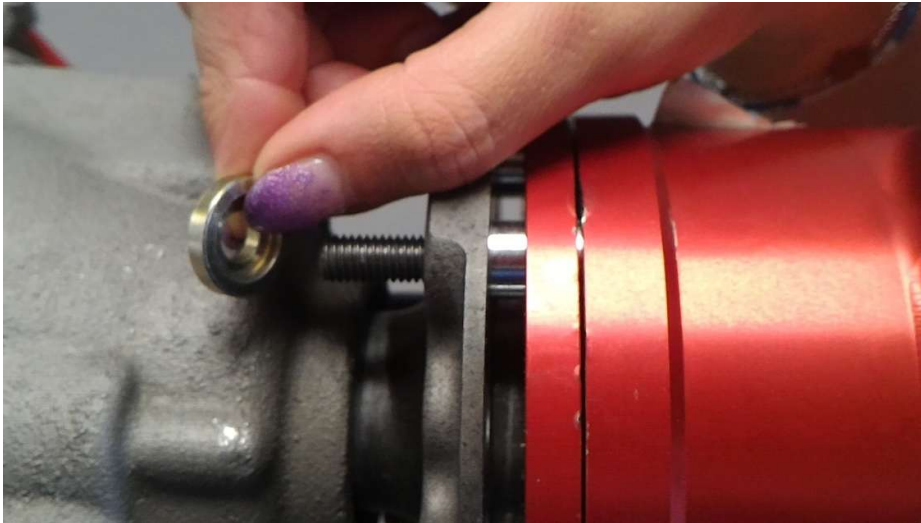

Fig. 4.4



Fig. 4.5

d) Insert the self-blocking nuts at the base of hub. Tighten the nut on the rear of the flange. Proceed to criss-cross fashion, gradually tightening up to completely pull the base of the hub flange. Tighten the bolts with torque of 2 kg*m.

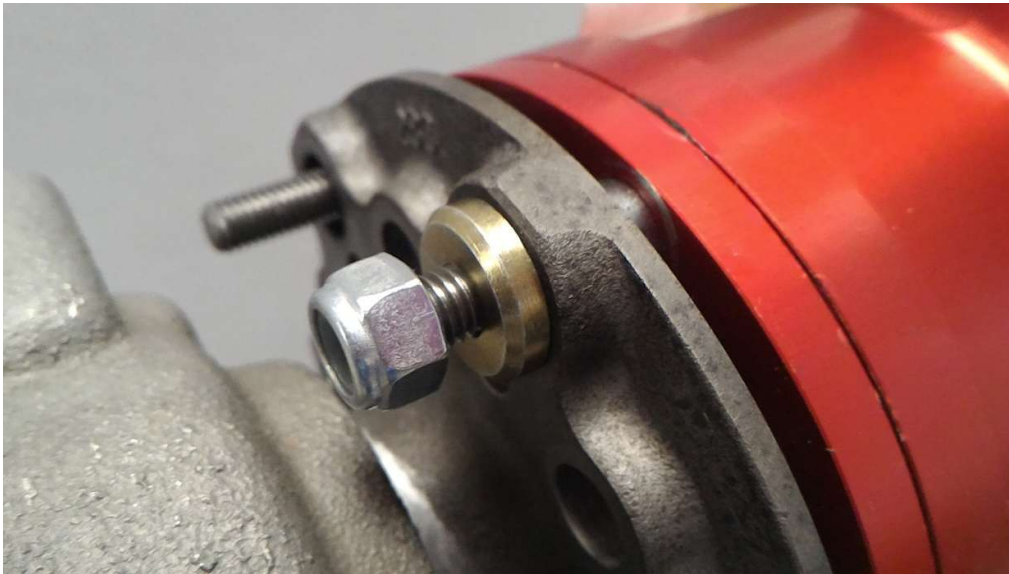

Fig. 4.6

NOTICE

e) Assemble the blades as follows. **Bring the blade and the blade seat having the same number**



Fig. 4.7

f) Point the blade seat up and put in the package bearing (washer +cage+ washer).



Fig. 4.8

g) Align the bronze sliding block at the center of the window. Looking at the alignment of the block and the hole in the center, insert the blade shank.



Fig. 4.9

h) Check the entry and verify that the rotation of the blade is locked. Screw the ring seal on to the thread and making sure the screw is going smooth.



Fig. 4.10

i) Continue tightening down with the compass wrench provided, using the 2 bolts provided (or other 2 bolts M6x12)



Fig. 4.11

To complete the tightening, it is necessary to use a torque key, with a wrench tool for torque key. [Fp-propeller code: CK-125/6]



Fig. 4.12



Fig. 4.13 [CK125/6]

⚠ WARNING

time.

To obtain the complete packing of the bearings, it is necessary to repeat 3 packing cycles, tightening to 2 Kg * m and loosening the sealing ring half of a turn each

⚠ WARNING

Finally tighten the ring nut with a torque of 2 kg * m.

This multi-cycle clamping operation serves to eliminate the play at the root of the blade without applying excessive tightening.

The real torque is greater than the nominal one by 22.6% due to the shape of the wrench tool CK/6 and that we have implied the above correction.

l) **Remove the 2 M6x12 bolts on the ring** and insert the locking plate in position.

Use the 2 M6x25 bolts (WITH HOLES) provided to fix the plate



Fig. 4.14

⚠ WARNING

Bolts tightening torque: 1,2 Kg * m.

⚠ WARNING

Flying with loose sealing rings can seriously damage the propeller and the engine. The washers and bearings located between the blade and the hub can crack or be damaged in case of excessive vibrations due to the not complete tightening of the sealing rings on the hub.

m) Use 1mm diameter stainless steel wire to bind the 2 bolts.

⚠ WARNING

The binding must prevent the screws from unscrewing



Fig. 4.15

Once the blade tightening operation has been completed, we suggest to mark with paint (eg CrossCheck Torque Seal) the angular position of the sealing ring respect to the hub.

In this way it is immediately possible to identify any unscrewing of sealing ring



Fig. 4.16

	INSTALLATION AND MAINTENANCE MANUAL	Code	MAN-0008e
		Revision #	02
		Last revision date	12/03/2025
PAGE .18 of 37	PROPELLER WITH HYDRAULIC SYSTEM		

⚠ WARNING Flying with loose sealing rings can seriously damage the propeller and the engine. The washers and bearings located between the blade and the hub can crack or be damaged in case of excessive vibrations due to the not complete tightening of the sealing rings on the hub.

n) Start the engine and spin the propeller for a few minutes at fixed point at 4500-5000 rom.

⚠ WARNING Stop the engine and repeat blade ring tightening and nut locking (previous point 3i and 3m).

o) The propeller is supplied with the possibility to change the angular pitch between the useful interval.

The range of the pitch limits is set to "standard" values, (15 ° -27 °), usually suitable for the Rotax 912 engine and the most widespread aircraft.

The value of the angular step is measured, as per convention, at 75% of the blade radius

5. SPINNER INSTALLATION

Proceed to unscrew the spinner screws, set aside the spinner and the closing strips.



Fig. 5.1

Secure the spinner plate to the flange at the base of the hub using screw, washer, washer, self-locking nut (x6). The edge of the plate goes towards the base of the hub.



Fig. 5.2 (two-blade electrical hub showed, installation is the same for any hub)



Fig. 5.3

Fig. 5.4

Go back to point 3f and complete the installation of the propeller.
Once the installation is finished, fix the spinner closing strips on the plate following the numbering shown on the strips and plate.
Complete by inserting the spinner and screwing the screws to the plate (screws + plastic washer).

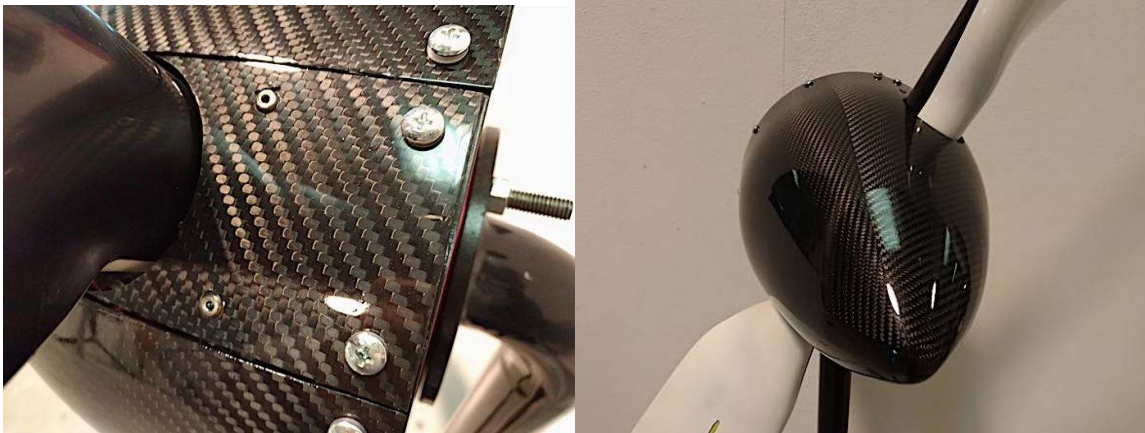



Fig. 5.5

Fig. 5.6

For subsequent checks of the hub / blade assembly, it is not necessary to remove the closing strips.

 fp propeller AIRCRAFT AND UAV PROPELLERS	INSTALLATION AND MAINTENANCE MANUAL	Code	MAN-0008e
		Revision #	02
		Last revision date	12/03/2025
PAGE .21 of 37	PROPELLER WITH HYDRAULIC SYSTEM		

6. PROPELLER BALANCING:

NOTICE

The propeller propellers are supplied dynamically balanced on the bench. **In any case, it is necessary to perform a definitive balancing procedure once installed on the plane and with the spinner mounted.**

Use an accurate tool for measuring the amount and position of dynamic unbalance. After balancing, the residual unbalance must be equal to or less than 0.4 ips. If the imbalance is higher than 1.2 ips, the propeller must be removed from the aircraft and dynamically rebalanced on the bench.

It is recommended to position the balancing weights radially on the spinner plate.

The balancing weights can be applied inside the plate, with scrupulous gluing or, more preferably, with a through rivet.

 fp propeller AIRCRAFT AND UAV PROPELLERS	INSTALLATION AND MAINTENANCE MANUAL	Code	MAN-0008e
		Revision #	02
		Last revision date	12/03/2025
PAGE .22 of 37	PROPELLER WITH HYDRAULIC SYSTEM		

7. END STOP ADJUSTMENT

NOTICE

The end stop adjustment is to be made if the engine, at full throttle, don't reach the top rpm or is overdrive.

If these conditions are found in the engine test at fixed point, then the idle limit must be adjusted. If, on the contrary, these conditions are found in horizontal flight, then the maximum limit must be adjusted.

⚠ WARNING

A Hydraulic propeller Governor like Jihostroj or MT-propeller is required to drive the propeller

Minimum and maximum pitch are controlled by Hydraulic governor.

⚠ CAUTION

The propeller has mechanical minimum and maximum end-run that have to be set to allow the properly work of the Hydraulic governor

7.1 Adjustment of the mechanical minimum end-run.

Loosen the retaining screw on the cap, remove the cap, loosen the retaining screw on the first nut, remove the first nut, loosen the retaining screw on the second nut.

Now, screwing or unscrewing the nut will increase or decrease the mechanical minimum end-run.



Fig. 7.1

when the correct minimum end-run is reached, lock the the retaining screw, put the second nut and lock the screw.

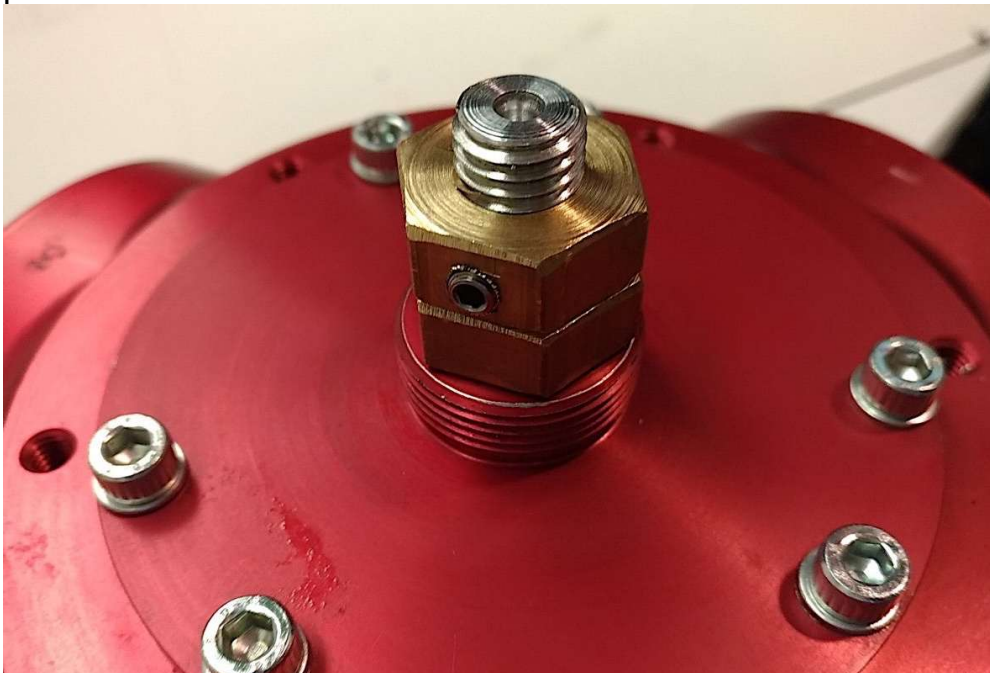



Fig. 7.2

use medium threadlocker for the retaining screws (e.g. type AREXON SYSTEM 52A43 – LOCTITE 243)

 fp propeller AIRCRAFT AND UAV PROPELLERS	INSTALLATION AND MAINTENANCE MANUAL	Code	MAN-0008e
		Revision #	02
		Last revision date	12/03/2025
PAGE .24 of 37	PROPELLER WITH HYDRAULIC SYSTEM		

7.2 Adjusting the mechanical maximum end run.

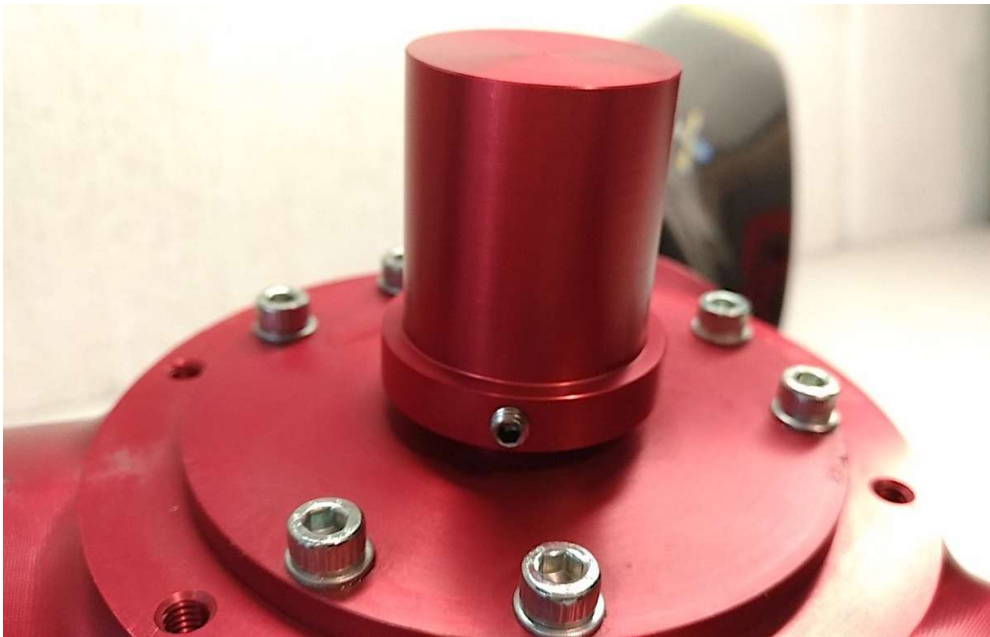



Fig. 7.3

Screwing or unscrewing the cap will decrease or increase the mechanical maximum end-run.

When the correct maximum end-run is reached, lock the retaining screw. Use medium threadlocker for the retaining screw (e.g. type AREXON SYSTEM 52A43 – LOCTITE 243)

 fp propeller AIRCRAFT AND UAV PROPELLERS	INSTALLATION AND MAINTENANCE MANUAL	Code	MAN-0008e
		Revision #	02
		Last revision date	12/03/2025
PAGE .25 of 37	PROPELLER WITH HYDRAULIC SYSTEM		

8. MAINTENANCE OPERATION

CAUTION

The in flight variable pitch propeller is a machine in the mechanical meaning of the term. For this reason, it must be kept in optimal conditions during operation, through regular checks and maintenance operations.

WARNING

Without mandatory inspections being regularly performed, the propeller is not airworthy and must not be used

8.1 Pre-flight checks:

The following checks must be carried out before each flight:

1. Check the general conditions of the propeller
2. Check the leading edge of all blades for possible impact damage.
Damages larger than 5 mm and damages that have perforated the protective edge are not accepted and are to be repaired
3. Check the shank area of each blade. Cracks or delaminations are not accepted in any case.
4. Check the status of the propeller assembly:
 - With the blade facing upwards, apply a slight alternating twist to the blade. An imperceptible movement of the shank and relative to the blade fixing ring nut is accepted. Relative movement is not acceptable
 - Positioning the blade facing upwards in front of the propeller, rest the index finger in contact with the blade shank and the blade and the blade retention ferrule in its seat; with the other hand, apply a slight alternating flexion of the blade in the direction of the main axis of the aircraft. The presence of backlash is felt with great sensitivity. In the presence of backlash, tighten the ring nut, according to the technique already described in chapter 4e-4m of the propeller assembly.



Fig. 8.1

⚠ WARNING

The presence of significant backlash in the fixing ring nut can be very harmful to the integrity of the propeller. In particular, under particular clearance conditions and elastic constants of the system, resonance oscillations can be triggered which can cause cracks and subsequent fatigue failures of some components.

5. Check for any ligatures and tightening bolts of the propeller to the flange
6. Check the spinner fixing bolts
7. Check the collector and current transmission brushes
8. Check the blades: if you see any changes in the surface such as roughness, cracks, bubbling or discoloration, **DO NOT operate your propeller**

 fp propeller AIRCRAFT AND UAV PROPELLERS	INSTALLATION AND MAINTENANCE MANUAL	Code	MAN-0008e
		Revision #	02
		Last revision date	12/03/2025
PAGE .27 of 37	PROPELLER WITH HYDRAULIC SYSTEM		

8.2 HUB AND METAL SHANKS SCHEDULED MAINTENANCE

WARNING

Checking and tightening blades, after installation, at: 5 hours, 25 hours and 50 hours Every 100 hours/ 1 year (whichever occurs

WARNING

first) , inspection and mandatory maintenance according to the following procedure

The 100 hours inspection may be performed by the Manufacturer or by an Authorized maintenance workshop.

CAUTION

Before any intervention, make sure that the engine is safe from accidental starting.

- a) Remove the spinner from the propeller and check for cracks. Cracks on the spinner are not allowed.
- b) Check the hub for cracks or oxidation areas. In the presence of oxidation, clean the oxide with fine sandpaper and protect the surface. The presence of cracks is not allowed. If in doubt, examine the presence of cracks with the penetrating ink technique and contact the Manufacturer immediately
- c) Remove each blade in sequence from its seat, by performing the reverse operations in the seat described in par 4e-4m. In particular: unscrew the ring nut with the appropriate key; with a slight oscillating movement, remove the blade from its seat
- d) Open the two roller bearings of the blade, clean the grease and examine the condition of the components. The bearing washers must be free from corrosion and cracks. In case of cracks, contact the Manufacturer. Broken rollers, roughness and teeth on the bearings are not allowed. In case of one of these defects, contact the Manufacturer. In case of corrosion, wash with WD40 or equivalent, using a brass wire metal brush



Fig. 8.2



Fig. 8.3

If corrosion has affected the washers, the bearings must be changed. This corrosion of the bearings can only take place if water has entered the hub, due to rain, washing with a lance at direct pressure towards the hub or due to condensation due to environmental weather conditions. Prevent water from entering the hub by suitable protections. If corrosion is detected, this maintenance must be repeated at closer intervals in order to protect the parts with lubricant.

The recommended grease is: AEROSHELL GREASE 22.

- e) Thoroughly clean the anchor flange and the base of the shank. Check the entire circumference, near the connecting radius, under optimal lighting, for cracks in the indicated area. In case of cracks, contact the manufacturer immediately



Fig. 8.4

- f) Grease the two bearings with grease with high adhesion to the steel (AEROSHELL GREASE 22), reposition the bearings and reassemble the blade in its seat as described in par 4e-4m



Fig. 8.5



Fig.8.6

 **CAUTION**

Note: the blade shank cannot be disassembled but is irreversibly cemented or structurally inserted during blade construction.

- g) Reassemble the spinner as described in the CHAP. 5

 fp propeller AIRCRAFT AND UAV PROPELLERS	INSTALLATION AND MAINTENANCE MANUAL	Code	MAN-0008e
		Revision #	02
		Last revision date	12/03/2025
PAGE .30 of 37	PROPELLER WITH HYDRAULIC SYSTEM		

8.3 **BLADES SCHEDULED MAINTENANCE**

Sensenich blades, check:

3B0R5 Installation Instructions rev-C-2018-10-02

Chapter:

- INSTRUCTIONS FOR CONTINUED AIRWORTHINESS
- INSPECTIONS
- REPAIRS

only for what concerns the blades

Fp-propeller blades:

Every 100 hours/ 1 year (whichever occurs first)

Visual inspection for deformation, wear, and cracks. Inspect the entire length of each blade looking for any leading-edge damage, fractures or finish wear.

If major repairs are necessary, return the propeller to the Fp-propeller factory for inspection and repair/replacement.

 fp propeller AIRCRAFT AND UAV PROPELLERS	INSTALLATION AND MAINTENANCE MANUAL	Code	MAN-0008e
		Revision #	02
		Last revision date	12/03/2025
PAGE .31 of 37	PROPELLER WITH HYDRAULIC SYSTEM		

9. SPECIAL CHECKS

⚠ WARNING In order to ensure maximum flight safety, it is required to carry out, in the long term, the control of the cracks on the hub (par 8b) and on the blade shank (par 8e) by means of penetrating ink and magnetoscopy techniques respectively.

These techniques are non-destructive and, in order to give reliable result, they must be carried out by skilled people.

These checks must be carried out:

- When purchasing a used aircraft.
- After an accident in which one or more blades were broken
- Every 500 flight hours.

If the technician who can perform these special checks is not in the area, contact the FP-propeller, who will carry out the tests and issue the relative certificate. For this purpose, the propeller must be dismantled from the aircraft and sent to the company.

10. PARTS TIME BETWEEN OVERHAUL (TBO)

- HUB: 2000 hours/6 years (whichever occurs first)
- Blades manufactured by Fp-propeller: 2000 hours/6 years (whichever occurs first)
- Blades from other manufacturer: the warranty provided by the manufacturer will be applied

Upon expiry of the TBO, the propeller must be sent to FP-Propeller, which will establish a possible further period of use based on the state of efficiency / wear that will be found on the interested parties. Any repairs will not in any case be useful to reset or reduce the service age of the affected component.

 fp propeller AIRCRAFT AND UAV PROPELLERS	INSTALLATION AND MAINTENANCE MANUAL	Code	MAN-0008e
		Revision #	02
		Last revision date	12/03/2025
PAGE .32 of 37	PROPELLER WITH HYDRAULIC SYSTEM		

11. IDENTIFICATION

Fp-propeller products are identified by a combination of letters and numbers:

Example: **VPH6-TE-R75DN**

Where:

Manufacturer: **V** denotes “FP-PROPELLER”

Product: **P** denotes “Variable pitch propeller”

Dimensions: **H6** or **H3** denotes “hub size”

Configuration: **T** denotes “three-blade propeller”, **B** denotes “two-blade propeller”

Type: **H** denotes “Hydraulic hub” , **E** denotes “Electric hub”

Blades type: final parts of the code **-R75DN** denotes “blades type”

Hub code is labeled on the hub, blades code is labeled on the rear of each blade, near the shank.

Same code and serial numbers are written on the provided PROPELLER LOGBOOK.

Annex A shows the possible combinations HUB/blades and the technical data.

 fp propeller AIRCRAFT AND UAV PROPELLERS	INSTALLATION AND MAINTENANCE MANUAL	Code	MAN-0008e
		Revision #	02
		Last revision date	12/03/2025
PAGE .33 of 37	PROPELLER WITH HYDRAULIC SYSTEM		

12. ANNEX A

LIST OF APPROVED BLADES

HUB VPH3-BH

Propeller code [VPH3-BH-HHS]

- **Blade type:** FP-propeller model HHS
- **Propeller diameter:** 1750 mm
- **Weight :** 8,40 kg
- **Moment of inertia:** 3.700 kg*cm²

HUB VPH3-TH

Propeller code [VPH3-TH-HHS]

- **Blade type:** FP-propeller model HHS
- **Propeller diameter:** 1750 mm
- **Weight :** 10 kg
- **Moment of inertia:** 5.600 kg*cm²

Propeller code [VPH3-TH-MS]

- **Blade type:** FP-propeller model MS
- **Propeller diameter:** 1750 mm
- **Weight :** 11 kg
- **Moment of inertia:** 6.800 kg*cm²

Propeller code [VPH3-TH-R68CN]

- **Blade type:** Sensenich model R68CN
- **Propeller diameter:** 1780 mm
- **Weight :** 9.2 kg
- **Moment of inertia:** 4.700 kg*cm²

HUB VPH6-BH

Propeller code [VPH6-BH-L69EN]

- **Blade type:** Sensenich model L69EN
- **Propeller diameter:** 1780 mm
- **Weight :** 8.1 kg
- **Moment of inertia:** 3.500 kg*cm²

Propeller code [VPH6-BH-R70EN]

- **Blade type:** Sensenich model R70EN
- **Propeller diameter:** 1780 mm
- **Weight :** 8.1 kg
- **Moment of inertia:** 3.500 kg*cm²

Propeller code [VPH6-BH-R75DN]

- **Blade type:** Sensenich model R75DN
- **Propeller diameter:** 1900 mm
- **Weight :** 8.3 kg
- **Moment of inertia:** 3.600 kg*cm²

Propeller code [VPH6-BH-GARW2B]

- **Blade type:** Whirlwind RW2B
- **Propeller diameter:** 1820 mm
- **Weight :** 8.1 kg
- **Moment of inertia:** 3.600 kg*cm²

HUB VPH6-TH

Propeller code [VPH6-TH-L69EN]

- **Blade type:** Sensenich model L69EN
- **Propeller diameter:** 1780 mm
- **Weight :** 10.3 kg

- **Moment of inertia:** 5.200 kg*cm²

Propeller code [VPH6-TH-R70EN]

- **Blade type:** Sensenich model R70EN
- **Propeller diameter:** 1780 mm
- **Weight :** 10.3 kg
- **Moment of inertia:** 5.200 kg*cm²

Propeller code [VPH6-TH-R75DN]

- **Blade type:** Sensenich model R75DN
- **Propeller diameter:** 1900 mm
- **Weight :** 11.5 kg
- **Moment of inertia:** 7.400 kg*cm²

Propeller code [VPH6-TH-GARW2B]

- **Blade type:** Whirlwind RW2B
- **Propeller diameter:** 1820 mm
- **Weight :** 10.0 kg
- **Moment of inertia:** 5.700 kg*cm²

	INSTALLATION AND MAINTENANCE MANUAL	Code	MAN-0008e
		Revision #	02
		Last revision date	12/03/2025
PAGE .36 of 37	PROPELLER WITH HYDRAULIC SYSTEM		

CONDITIONS FOR SALE

1- SALES are made under the general conditions of the selling Company. They can not be altered unless by the selling Company and by written document. All sales are intended as to be "subjected to approval by the seller". Within 15 days fro receipt of the purchase order, the seller will send wrtten confirmation.

Fp-propeller Srl reserves the right to refuse the order.

2- ESTIMATES AND TECHNICAL DATA. Estimates by the seller are not binding. Illustrations, measurements, weights and all the characteristic data resulting from catalogs must be considered as approximate values. They are communicated by the seller for information only and without responsibility. The seller reserves the right to make changes to its products without prior notice and without obligation to apply such changes retroactively.

3- DELIVERY. The sold material will be delivered as soon as possible, subject to the commitments outstanding and to the possibility of production by the factory. The delivery time is therefore only indicative term. It does not constitute an essential condition of the contract. .The delivery term is adequately extended by effect of events independent from the will of the supplying company. In any case, the customer may not claim damages or other related to late delivery.

4- TRANSPORT. The sale of goods is carried out "ex works." It travels under full risk and peril of the customer. The eventual loss or damage of the goods shall not give rise to claims to the seller for damages. The transport insurance will only be made if requested by the customer and at his charge; The request of insurance must be made explicit in the order.

5 PRICES AND TERMS OF PAYMENT. FP-propeller Srl. may modify its prices at any time. The payments of the supply must be made within the period reported in the order confirmation, signed for acceptance by the customeer. For any dispute concerning the material supplied or for any other divergence the Buyer may not suspend payments. Failure to pay the agreed price even for only one part, the non-compliance with contractual obligations and failure by the buyer of one of the above conditions, entitle FP-propeller Srl to obtain immediate completion of all obligations assumed by the buyer, or termination of the contract being worth this as a termination clause about. Delay in paying in the agreed deadlines by the Purchaser, entitles the supplier to apply the monthly interest at the reference rate EURIBOR + 5 points.

6- TERMINATION. In case of contract termination due to breach, the payments in advance alreay done will remain acquired by the seller Company as indemnity, except the eventual more damage. In any case it will be due to the seller, as a penalty, a sum equal to 15% of the value of sold material, always subject to the most damage.

7-RESERVE OF PROPERTY. The seller, according to Article 1523 Cod. Civ., keeps the property of the material sold until the full pyment of the agreed price. Therefore, the object of the supply will pass to the Buyer property only with the completion of the amount due, while assuming the same risks from the time of delivery. Under request of the seller and in charge to the buyer, it will be provided to all the formalities required by art. 15234 Cod .. Civ. for which the buyer agrees the same at any time.

8-WARRANTY. Products of the FP-PROPELLER S.R.L. They must be installed, maintained and used as specified in the instruction manual provided. Failure to follow these instructions cancels,

	INSTALLATION AND MAINTENANCE MANUAL	Code	MAN-0008e
		Revision #	02
		Last revision date	12/03/2025
PAGE .37 of 37	PROPELLER WITH HYDRAULIC SYSTEM		

erases all the responsibility for FP-propeller Srl. The propeller user always flies under his entire responsibility. The Company FP-propeller Srl guarantees its products for six months after delivery. The warranty covers free repair or replacement of parts that presented established defects in materials, construction, or workmanship; it takes place after examining and finding faults and their causes, to be made by the seller and at its workshops or in those which are authorized to do so. The costs of any inspections, granted by the seller, for transportation to repair or replace, as well as the hand work for the installation thereof shall on charge of the buyer. The warranty is not transferable to third sub-buyers and ceases if products are used in a manner inconsistent with the instructions of the house; if they are dismantled, repaired, modified, also in part, without the permission and the control of the seller or its delegates. All parts subjected to wear and tear during the use are not covered by the warranty.. For parts not manufactured by the seller, the warranty is supplied directly from the manufacturer of the part itself. In any case, it is limited to the warranty limits granted by that manufacturer. Furthermore, the use of the propellers for the flight must be made by applying strictly the instructions and the control procedures, to ensure maximum safety. **Therefore, under no circumstances, the buyer may demand compensation for any damages due to the use of the propeller.**

9- COMPLAINTS. Any complaint must be received by the supplier within eight days of receipt of goods by the customer. Claims for breakages or missing parts compared to the delivery document should be communicated to the carrier upon receipt. The complaint does not release the buyer from the obligation to withdraw other regularly ordered goods ready for delivery or allow him to reduce or suspend the payments agreed

10- JURISDICTION for all disputes related to this contract, both parties Buyer and Supply recognize the competence of FERRARA COURT