

IN-FLIGHT VARIABLE PITCH PROPELLER WITH ELECTRIC SERVO MOTOR SYSTEM

**TYPE : VPH3 / VPH5 / VPH6
(HUB TYPE A / B)**

INSTALLATION AND MAINTENANCE MANUAL

N.B. THIS PROPELLER IS WITHOUT CERTIFICATION. ANY RESPONSABILITY IN THE USE OF THIS PROPELLER IS IN CHARGE TO THE USER

IMPORTANT WARNINGS

- The variable pitch propeller is a "machine" performing its operations during the flight of the aircraft. This is the reason why the pilot must know in deepness how it works.
- Wrong commands to the pitch of the propeller can greatly reduce the flight safety.
- It is strongly recommended that pilot asks for authorized personnel only, for installation, maintenance and operating instructions.
- The propeller is a component of the aircraft subjected to great stress and to constant overall vibratory system.
- Our propellers are made by selected and certified materials, according to widely proven techniques in order to ensure high safety factors of each component.
Unfortunately, we do not have useful tools to indefinitely ensure the propeller structure and its running in operational conditions so severe, and, in particular, in absence of adequate periodic maintenance.
- Therefore, as also required by law, it is pilot's responsibility to thoroughly check the propeller before each flight and carry out all checks of operation and maintenance reported in this manual
- In particular, these checks allow the pilot to highlight harmless problems (signs, cracks, surface etc.) before they become serious problems. Any abnormal behavior during use, along with any "signs" should be investigated in a preventative way, in order to act properly and promptly.

Revision control

Rev.	Change	Approved	Date
00	Initial release	FP	05/09/2016
01	Added Hub type B	FP	21/03/2017
02	Added Symbol used	FP	26/02/2018
03	Minor adjustments	FP	17/10/2019
04	Added Spinner installation	FP	23/11/2021
05	Added Ch.3 - Ch.11 - Annex A	FP	24/02/2022

Table of Contents

1. SYMBOLS USED	5
2. BEFORE INSTALLATION	6
3. PHYSICAL DESCRIPTION	7
4. PROPELLER INSTALLATION	9
5. SPINNER INSTALLATION	26
6. PROPELLER BALANCING:	28
7. END STOP ADJUSTMENT	29
7.1 Adjustment of the minimum end-run.....	30
7.2 Adjusting the maximum end run.....	31
8. PITCH ADJUSTMENT IN CASE OF ELECTRICAL FAILURE	33
9. MAINTENANCE OPERATION	35
9.1 Pre-flight checks.	35
9.2 HUB AND METAL SHANKS SCHEDULED MAINTENANCE	37
9.3 BLADES SCHEDULED MAINTENANCE	39
10. SPECIAL CHECKS	41
11. PARTS TIME BETWEEN OVERHAUL (TBO).....	41
12. IDENTIFICATION.....	42
13. ANNEX A.....	43

1. SYMBOLS USED

This Manual uses the following symbols to emphasize particular information. This information is important and must be observed.

 **WARNING**

Identifies the instruction which, if not followed, may cause serious injury including the possibility of death.

 **CAUTION**

Identifies the instruction which, if not followed, may cause minor or moderate injury.

NOTICE

Denotes the instruction which, if not followed, may severely damage the engine or other components.

2. BEFORE INSTALLATION

CAUTION

In order to avoid problems concerning the incorrect installation of your new propeller and therefore its correct operation, we strongly advise you to carry out the following checks on your aircraft:

- Check the correct carburation.
- Check the correct balance of the carburetors.
- Check the integrity of the propeller gearbox.
- Check the calibration of the springs in Rotax engines and that they are exclusively equipped with anti-tear clutch.
- Check the engine intake system if is not partially obstructed and if the maximum supply pressure can be achieved when the full throttle is entered.
- Carefully clean the contact surfaces of the motor flange with a light solvent, making sure that the flange itself has not been damaged by previous impacts of propellers on the ground.
- Check by authorized workshop that the run-out from the centering nose and the run- axial out are not out of tolerance as per the data of the engine manufacturer. In addition, make sure there is no deformation or surface scratching that could compromise the perfect coupling between the motor flange and the propeller flange.
- Carefully check the motor flange even on new engines.
- Propeller clearance: propeller installation must be compliant with: EASA CS22-SUB E – (CS 22.925)

3. PHYSICAL DESCRIPTION

The hub of the propeller is a single high strength component, manufactured from solid billet material. Other components within the propeller are machined from a variety of engineering materials.

Variable pitch propellers have an electrically operated pitch change mechanism.

The pitch change motor is an electric servomotor assembly incorporating gearbox, which operates a pitch change mechanism.

The pitch change mechanism incorporates a precision-engineered drive screw mechanism that controls the position of a pitch change slide.

The pitch change slide is moved along the axis of the propeller hub and acts upon a cam-follower attached to the base of each propeller blade assembly.

Movement of the pitch change mechanism therefore causes a corresponding change in blade angle on each propeller blade.

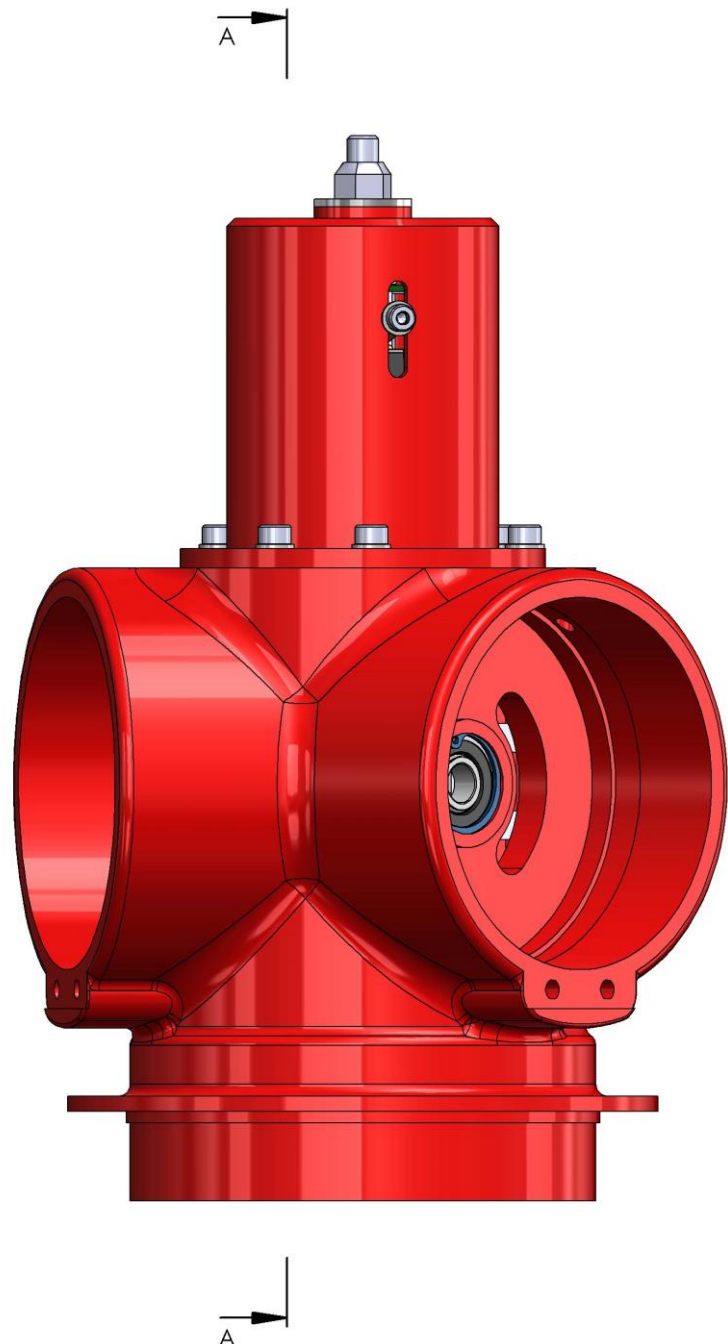

Fig. 3.1

In order to avoid dangerous pitch positions for the flight, the range of values is limited within the useful values, from take-off to cruise (fast and normal).

Usually, the minimum pitch is adjusted for maximum takeoff turns. On the other side, the maximum pitch is adjusted for the aircraft's VNE speed.

The adjustment of the step range is obtained with two microswitches (minimum and maximum)

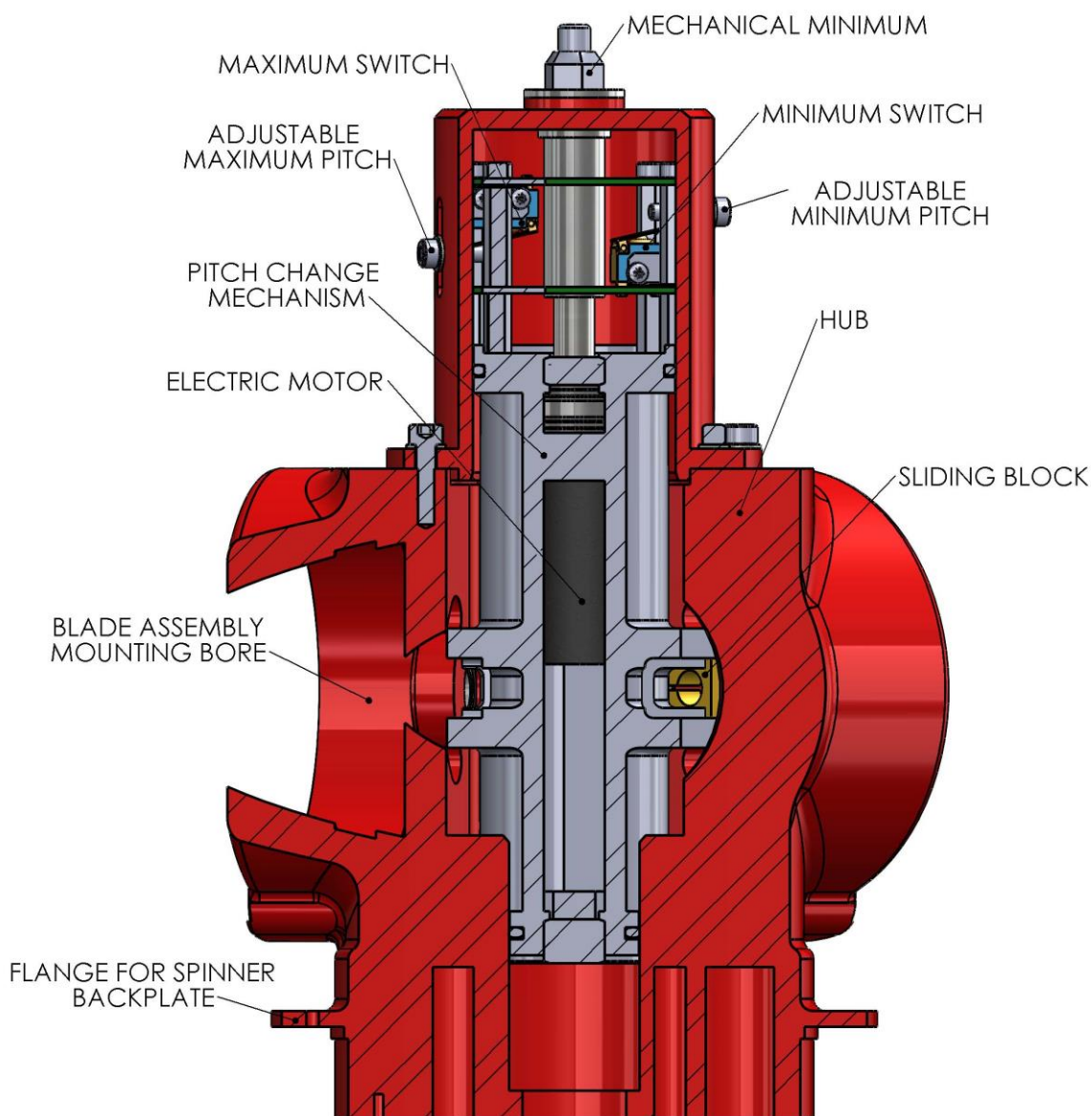

Fig. 3.2 AA SECTION

4. PROPELLER INSTALLATION

The installation technique here described is related to the Rotax engine with hollow reduction gear box (912,914). The hub can be type A or type B

For other engines without gearbox, contact the manufacturer.

HUB type A



Fig. 4.1

HUB type B



Fig. 4.2

Parts for the propeller installation for type A HUB



Fig. 4.3

Parts for the propeller installation for type B HUB



Fig. 4.4

a) Enter, from the engine compartment, the collector within the shaft bore in the gearbox.



Fig. 4.5



Fig. 4.6

b) Insert, side flange, the stopper.



Fig. 4.7

Pull cables in holes



Fig. 4.8

NOTICE

c) tighten the screw and block in the back of the gear box by washer + nut and strong thread blocking (e.g. type AREXON SYSTEM 52A70 – LOCTITE 290)



Fig. 4.9

d) assemble the brushes over the collector, by using the threaded holes already on the back of the gearbox.



Fig. 4.10

e) **TYPE A HUB.** Screw the M8 threaded rods into the flange and with the Allen print in the rear of the flange. Block the threaded rod by a standard nut from the rear of the flange.



Fig. 4.11

NOTICE

LOCTITE 290)

e) **TYPE B HUB.** Insert the studs in the bushes, by applying strong threadlocker (e.g. type AREXON SYSTEM 52A70 –



Fig. 4.12

Screw until **20 mm** of visible thread remains

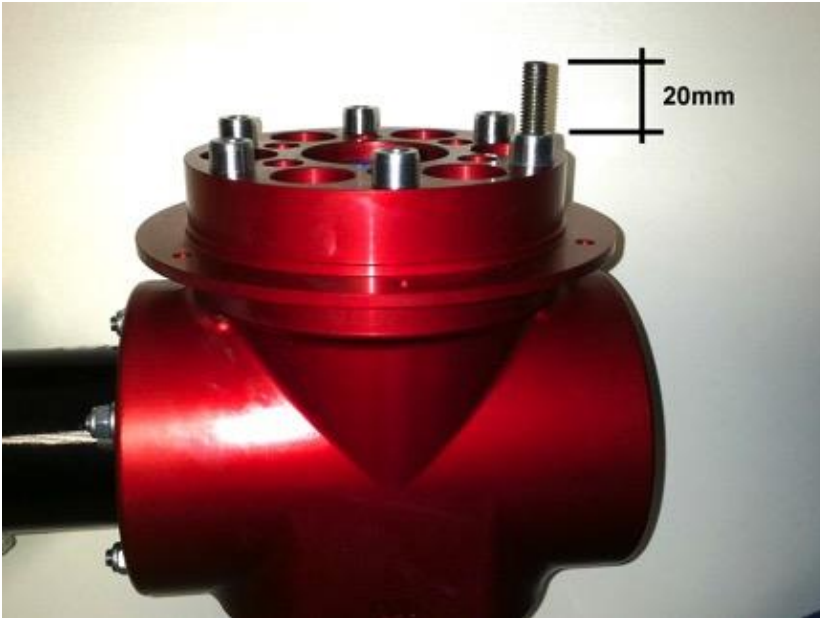

Fig. 4.13

NOTICE

In the case of installation **with spacer**, the projection from the stud to the spacer **must be 29mm**

In the case of installation with the Carbon deluxe model FP-propeller spinner, before proceeding to the next step, go to chapter 5 (Spinner installation). **FOR TYPE B HUBS ONLY**

f) Insert the shrinkable covers on the cables (two layers)



Fig. 4.14

g) hang the propeller hub to one of the M8 rods protruding from the flange. Connect the cables from the propeller to the collector.



Fig. 4.15

h) place the first shrinkable over the connections; heat the shrinkable with a heat gun. Place the second shrinkable over the first ones and heat again.

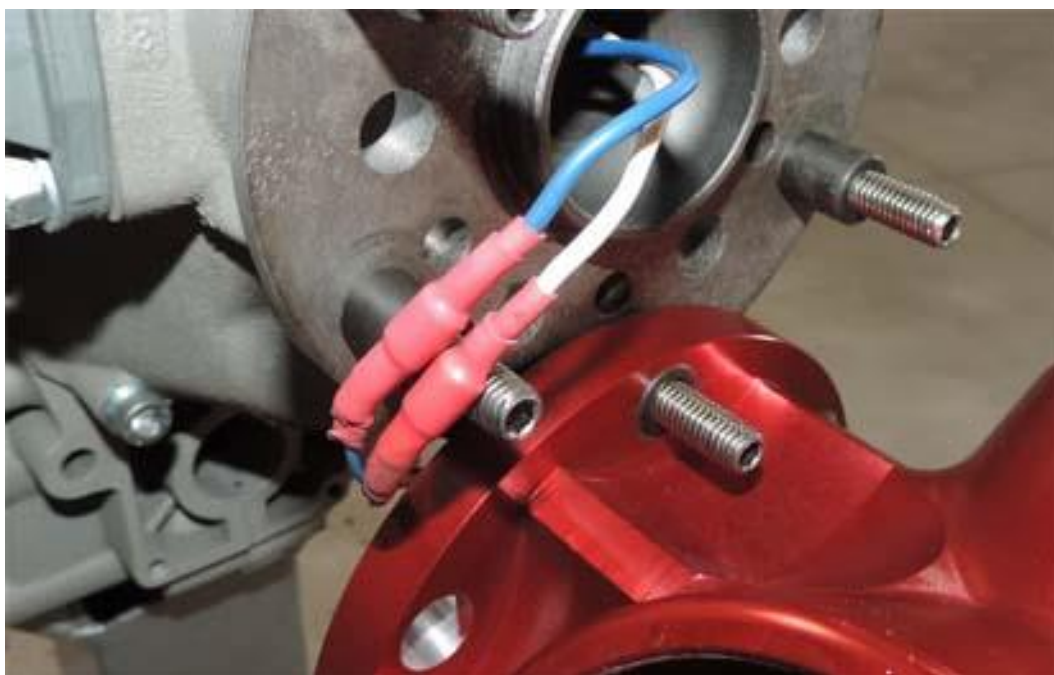

Fig. 4.16

i) **TYPE A HUB.** Insert the hub base in the flange.

⚠ CAUTION

In this operation, the newly connected cables must be carefully retracted into the central cavity, to prevent them from being cut or "chewed" when inserting the hub base into the motor flange, thus causing interruptions or short circuits.

Insert the special washers and the self-blocking nuts at the base of hub. The washer must be inserted with the cavity facing the protruding stud.

Tighten the nut on the rear of the flange and tighten the nut on the side of the hub.

Proceed to criss-cross fashion, gradually tightening up to completely pull the base of the hub flange.

⚠ WARNING

Tighten the bolts with torque of 2 kg*m.

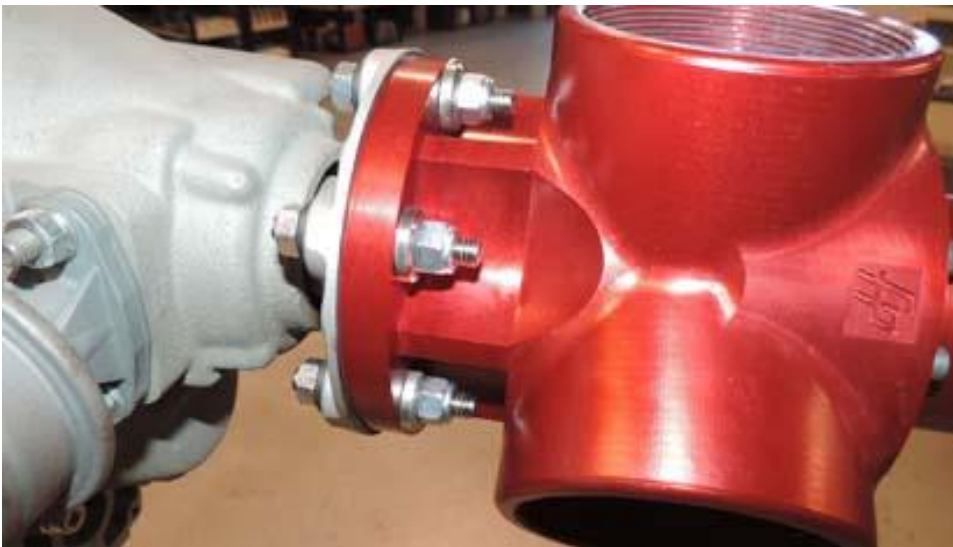

Fig. 4.17

i) **TYPE B HUB.** Insert the hub base in the flange.

⚠ CAUTION

In this operation, the newly connected cables must be carefully retracted into the central cavity, to prevent them from being cut or "chewed" when inserting the hub base into the motor flange, thus causing interruptions or short circuits.

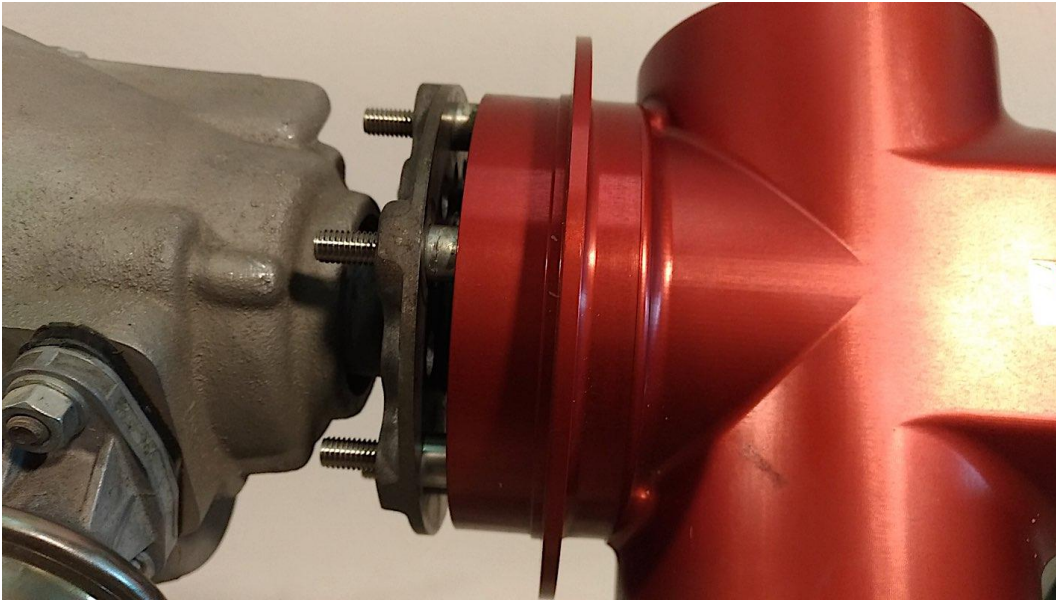

Fig. 4.18

Insert the special washers and the self-blocking nuts at the base of hub. The washer must be inserted with the cavity facing the protruding stud.

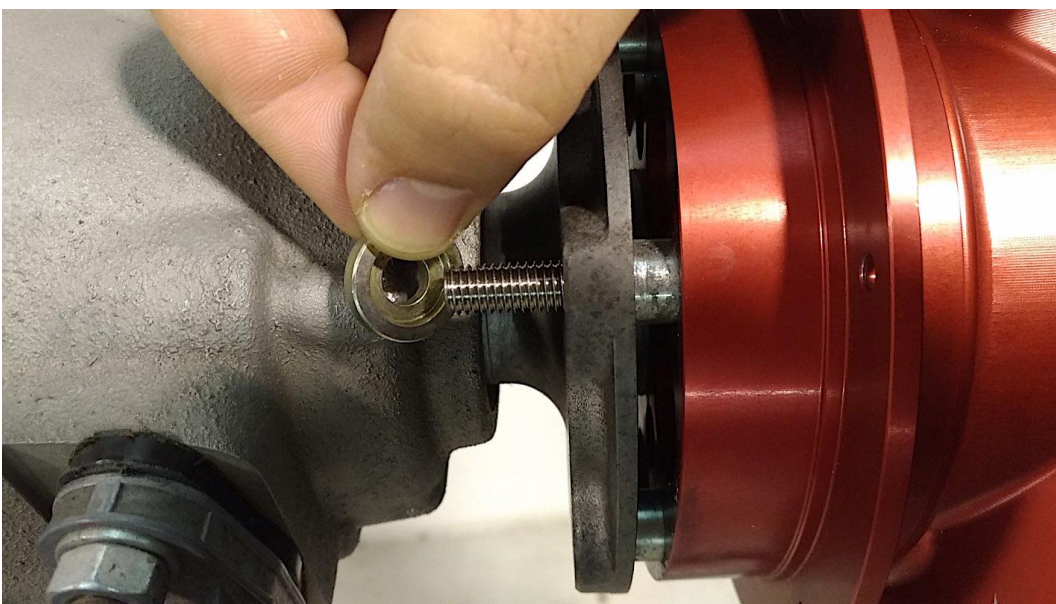

Fig. 4.19

Tighten the nut on the rear of the flange.

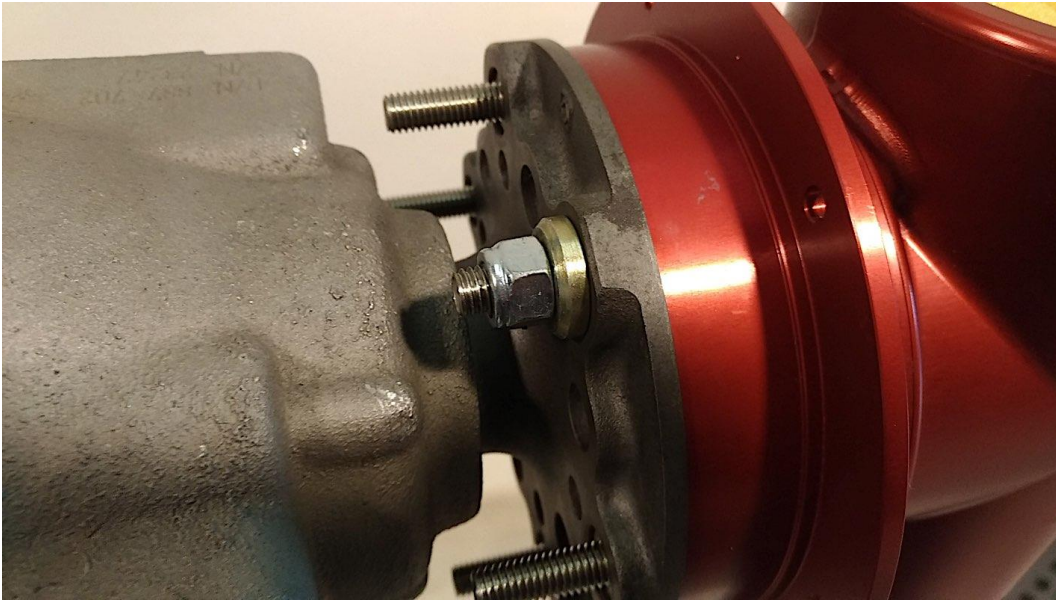

Fig. 4.20

Proceed to criss-cross fashion, gradually tightening up to completely pull the base of the hub flange.

⚠ WARNING

Tighten the bolts with torque of 2 kg*m.

NOTICE

l) Assemble the blades as follows. Bring the blade and the blade seat **having the same number.**



Fig. 4.21

m) Point the blade seat up and put in the package bearing (washer +cage +washer)



Fig. 4.22

n) Align the bronze sliding block at the center of the window. Looking at the alignment of the block and the holes in the center of the seat, insert the blade shank.



Fig. 4.23

o) Check the entry and after verifying that the rotation of the blade is locked, even without having screwed the retention ferrule.

Screw the retention ferrule manually on to the thread and making sure the screw is going smooth.



Fig. 4.24

p) Continue tightening down with the compass wrench using the 2 bolts provided (or other 2 bolts M6x12)



Fig. 4.25

To complete the tightening, it is necessary to use a torque key, with a wrench tool for torque key. [Fp-propeller code: CK-125/6]



Fig. 4.26



Fig. 4.27 [CK125/6]

⚠ WARNING

To obtain the complete packing of the bearings, it is necessary to repeat 3 packing cycles, tightening to 2 Kg * m and loosening the sealing ring half of a turn each time.

⚠ WARNING

Finally tighten the ring nut with a torque of 2 kg * m.

This multi-cycle clamping operation serves to eliminate the play at the root of the blade without applying excessive tightening.

The real torque is greater than the nominal one by 22.6% due to the shape of the wrench tool CK/6 and that we have implied the above correction.

q) Using a torque wrench, tighten the nuts protruding from the retention ferrule.

! WARNING

Nuts tightening torque: 1 Kg * m.

After this operation, check with the torque wrench that the sealing ring is locked. If the locking is not complete, tighten (and not exceed) to 1.5 kg * m



Fig. 4.28

Once the blade tightening operation has been completed, we suggest marking with paint (e.g. CrossCheck Torque Seal) the angular position of the retention ferrule in respect to the hub and also the position of the self-locking nuts.

In this way it is easy to identify any accidental unscrewing of of the ferrule.



Fig. 4.29

⚠ WARNING Flying with loose retention ferrule can seriously damage the propeller and the engine. The washers and bearings located between the blade and the hub can crack or be damaged in case of excessive vibrations due to the not complete tightening of the retention ferrule in the hub.

r) Connect the wires for the pitch control (governor or central return switch) with reference to the following concept scheme:

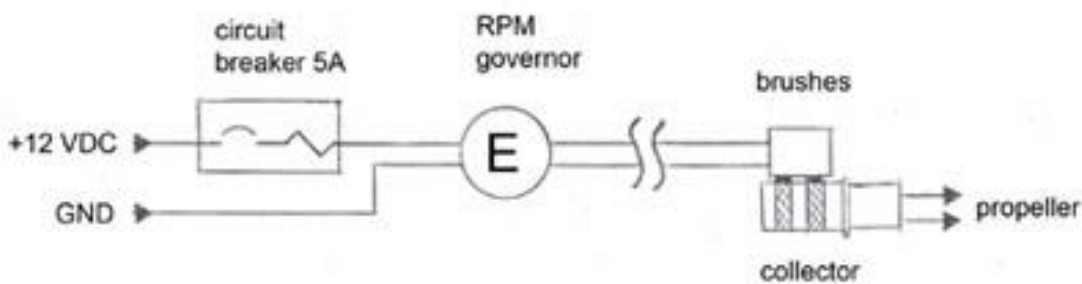

Fig. 4.30

Check that the direction of blades rotation (+) corresponds to the direction for the increase command of the pitch and vice versa for (-). If the case, reverse the wire connection. Set the pitch to the minimum limit.

In some governor, in place of (+pitch) and (-pitch) it is indicated (+ rpm) and (-rpm). In this case, when the (+ rpm) drive must occur, the angular pitch of the blade decreases. And vice versa, by operating (-rpm), pitch must increase.

Using the governor's manual control, bring the propeller pitch to the minimum pitch.

s) Start the engine and run the propeller for a few minutes at fixed point at 4500-5000 rpm. Carry out the operation after positioning the aircraft on gravel / pebbly free ground. Keep the aircraft braked.

The operation performs the 1st adjustment between the threads on the blade retaining ferrule.



WARNING Stop the engine. unscrew ½ turn the ring nuts locking the ferrule.

Repeat blade ring tightening and nut locking (previous point 4p and 4q).

t) The propeller is supplied with the ability to change the angular pitch just in-between the useful range.

The range of the pitch limits is set to "standard" values, (15 ° -27 °), usually suitable for the Rotax 912 engine and the most popular planes.

The value of the angular pitch is measured, as per convention, at 75% of the blade radius.

5. SPINNER INSTALLATION

Proceed to unscrew the spinner screws, set aside the spinner and the closing strips.



Fig. 5.1

Secure the spinner plate to the flange at the base of the hub using screw, washer, washer, self-locking nut (x6). The edge of the plate goes towards the base of the hub.



Fig. 5.2 (two-blade electrical hub showed, installation is the same for any hub)



Fig. 5.3



Fig. 5.4

Go back to point 3f and complete the installation of the propeller.

Once the installation is finished, fix the spinner closing strips on the plate following the numbering shown on the strips and plate.

Complete by inserting the spinner and screwing the screws to the plate (screws + plastic washer).

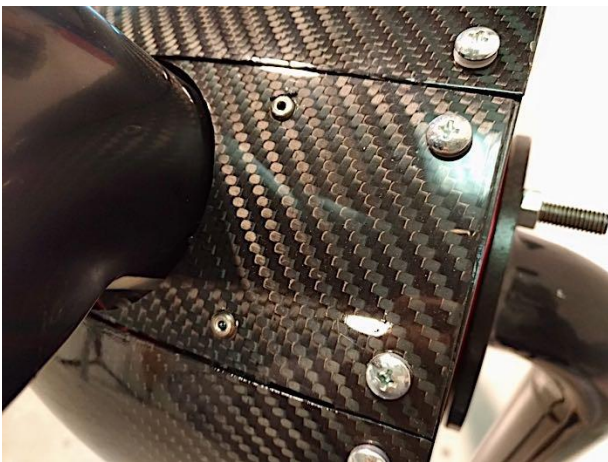

Fig. 5.5



Fig. 5.6

For subsequent checks of the hub / blade assembly, it is not necessary to remove the closing strips.

6. PROPELLER BALANCING:

NOTICE

The propeller propellers are supplied dynamically balanced on the bench. **In any case, it is necessary to perform a definitive balancing procedure once installed on the plane and with the spinner mounted.**

Use an accurate tool for measuring the amount and position of dynamic unbalance. After balancing, the residual unbalance must be equal to or less than 0.4 ips. If the imbalance is higher than 1.2 ips, the propeller must be removed from the aircraft and dynamically rebalanced on the bench.

It is recommended to position the balancing weights radially on the spinner plate.

The balancing weights can be applied inside the plate, with scrupulous gluing or, more preferably, with a through rivet.

7. END STOP ADJUSTMENT

NOTICE

The end stop adjustment is to be made if the engine, at full throttle, don't reach the top rpm or is overdrive.

If these conditions are found in the engine test at fixed point, then the idle limit must be adjusted. If, on the contrary, these conditions are found in horizontal flight, then the maximum limit must be adjusted.

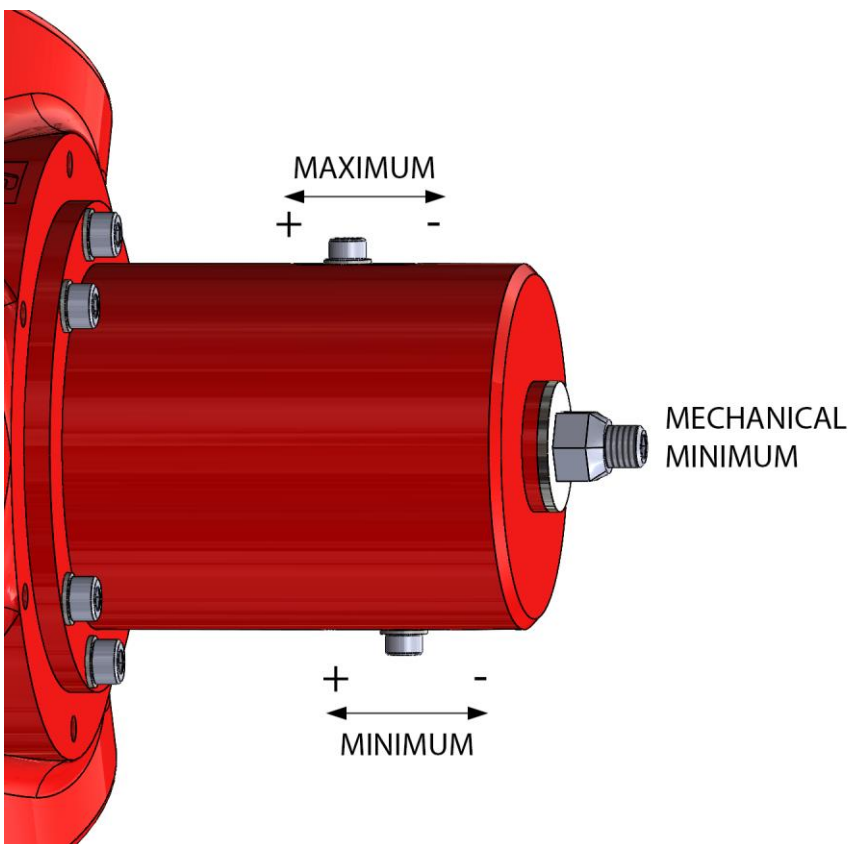

Fig. 7.1

Before proceeding with pitch adjustment, remove the mechanical minimum screw.

The adjustment of the pitch limit switch is made by adjusting the screws protruding from the box on the front of the hub. The idle screw is retracted, the maximum is closer to the hub, as shown in the picture.

7.1 Adjustment of the minimum end-run.

With the aircraft at fixed point, set the minimum pitch. Turn on motor and, gradually accelerating whether the motor reaches full throttle. There are 3 possibilities: a) the motor reaches the out-turn b) the motor reaches 5800 rpm c) the motor does not reach 5800 rpm.

a) case: the minimum is too low. Loosen the idle screw and move in the direction (+). Consider that 1 mm displacement of the screws a variation of the minimum of 2,5 degrees about. Tighten the screw and repeat the test engine. If the overdrive is not completely removed, repeat the whole cycle until to obtain the adjustment.

b) case: the minimum is adjusted as it is.

c) case: the minimum is too high. Loosen the nut and unscrew a few turn the screw in front of the box (minimum mechanical). Tighten the nut.

Then, loosen the screw of the end-run minimum and move it in direction (-). Again, consider that 1 millimeter of displacement of the screw produces a change in the idle pitch of 2,5 degrees. Tighten the screw and repeat the test engine. If the full rpm is not recofered, repeat the whole cycle up to get the adjustment.

Then, restore the mechanical minimum as follows.

- In the minimum pitch position, loosen the nut of the mechanical minimum.
- Then, seek contact with the shaft of the screw inside.
- Release the screw of 3/4 ride. Holding down the screw, lock the nut much. (figure 6.2)

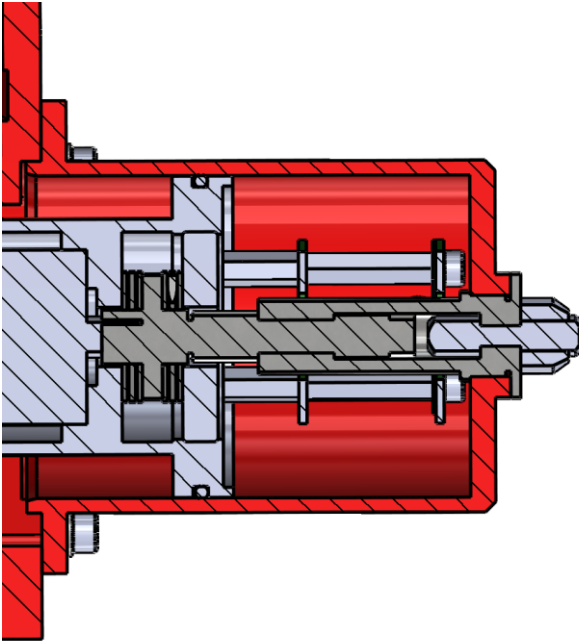

Fig. 7.2

⚠ WARNING

Please note that the mechanical minimum is a security stop in order to prevent blade pitch reverse. It is located 2 degrees (=3/4 ride) below the minimum end-run electrical system.

It is noted that the mechanical limit stops the electric motor but does not interrupt the electrical current.

Thus, the persistent drive of the electric motor against mechanical minimum will destroy the motor itself.

7.2 Adjusting the maximum end run.

Normal values of maximum pitch in propellers for Ultra Light aircrafts with a Rotax engine are in-between 25 and 30 degrees, depending on the aircraft top speed. Usually, the maximum pitch end run is positioned at 2-3 degrees above the top speed in level flight. As a rule, it is required that the maximum pitch does not exceed the aircraft's VNE

To adjust the maximum step, verify that, coarsely, at least 15 degrees of pitch range are available from the minimum pitch.

Then, make a first flight test. Flying in horizontal level, increase the engine set gradually to the maximum rpm.

If, moving towards the maximum speed, the step reaches the maximum end-of-stroke before having reached the maximum power, the engine can go in over-revs. In this case, land and increase the maximum limit switch by means of the respective screw, moving it towards the (+) by about 1 mm, with the same procedure illustrated above for adjusting the minimum.

Repeat the flight test and, if necessary, repeat the correction increasing the maximum end-run.

The adjustment is completed when, flying down 20 degrees about and with the engine at maximum power, there is no out-of-turn condition.

⚠ WARNING

If, in the flight test, the maximum engine speed is reached by still having ample space to increase the propeller pitch to the end-run, the maximum end-run value is exuberant.

In this case, land and reduce the maximum end-run by means of the respective screw, moving it in the (-) direction, as in the idle adjustment.

The adjustment is complete when, in flight leveled with full-power engine, the pitch of the propeller can still be increased by only two to three degrees.

8. PITCH ADJUSTMENT IN CASE OF ELECTRICAL FAILURE

- In case of electrical failure of the pitch driving system, the blade pitch remains fixed to a given value in the range between maximum and minimum or proceeds in one direction (partial failure)
- In all cases, after landing to be made as soon as possible, you should manually adjust the blade pitch to an optimal value and do nothing more to the pitch command. If the automatic governor is installed, switch to "manual". In this way, the propeller becomes in effect a "fixed pitch"
- To make the manual adjustment of the blade pitch, remove completely the mechanical end-run. Insert in the hole of the mechanical minimum removed an Allen wrench n. 5 and engage the screw that produces the change of pitch. Turning (slowly) the wrench clockwise, the pitch increases. Turning it counterclockwise decreases the pitch.
- In order to have this option easily effective, it is highly recommended to mark the useful pitch position on one of the blade shanks. This marking is made by applying an adhesive on the shank stem and aligned, the same adhesive on the corresponding locking ferrule.
- We mean "useful pitch" the blade pitch compromise between a "reasonable" take-off" and a "suitable" cruise speed. As an indication, this position may be the pitch, giving 4900 rpm at fixed point with full power. The useful pitch is easy to be found by the governor in manual mode. The technique is as follows:
 - place the aircraft at fixed point, bracked; go up with engine power and pitch until 4.900 rpm with full power.
 - stop the engine and apply the reference line on ferrule/blade shnk
- The marking of the useful pitch is to be done during the propeller set up or during the maintenance

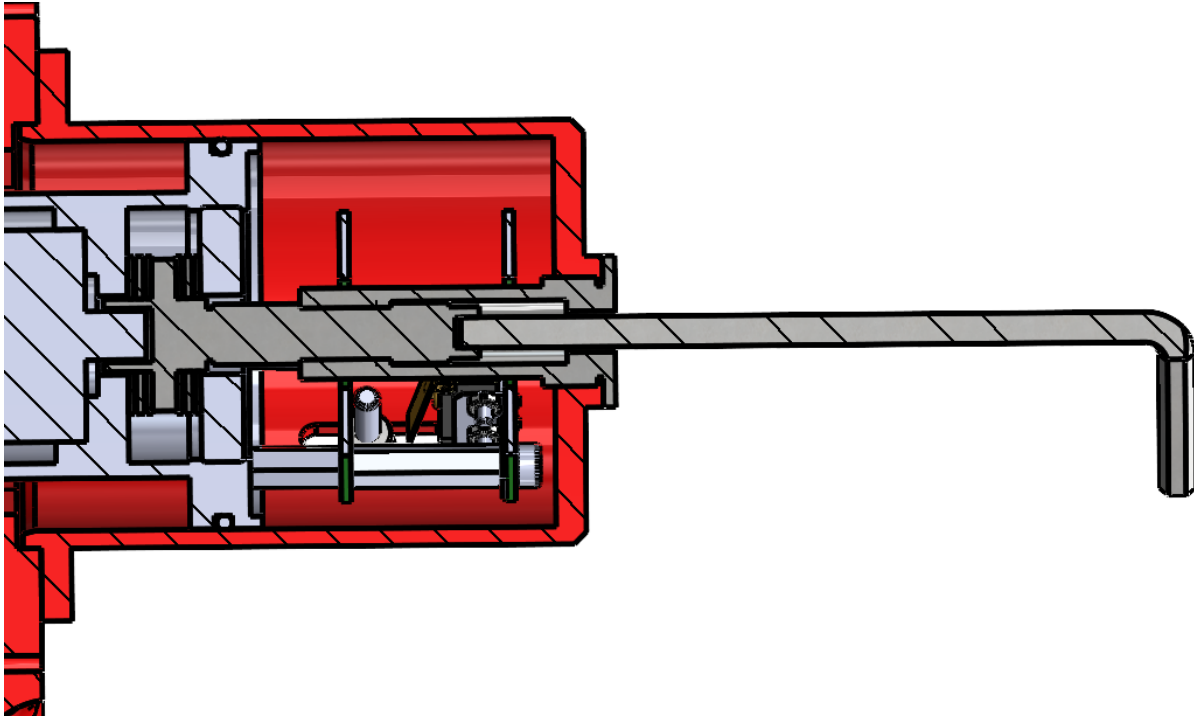

Fig. 8.1

 **WARNING**

In order to prevent any risk, take-off and landing must be carried out with governor in manual setting and without any pitch change command during these flights.

9. MAINTENANCE OPERATION

CAUTION

The in-flight variable pitch propeller is a machine in the mechanical meaning of the term. For this reason, it must be kept in optimal conditions during operation, through regular checks and maintenance operations.

WARNING

Without mandatory inspections being regularly performed, the propeller is not airworthy and must not be used

9.1 Pre-flight checks.

The following checks must be carried out before each flight:

1. Check the general conditions of the propeller
2. Check the leading edge of all blades for possible impact damage. Damages larger than 5 mm and damages that have perforated the protective edge are not accepted and are to be repaired
3. Check the shank area of each blade. Cracks or delaminations are not accepted in any case.
4. Check the status of the propeller assembly:
 - With the blade facing upwards, apply a slight alternating twist to the blade. An imperceptible movement of the shank and relative to the blade fixing ring nut is accepted. Relative movement is not acceptable
 - Positioning the blade facing upwards in front of the propeller, rest the index finger in contact with the blade shank and the blade and the blade retention ferrule in its seat; with the other hand, apply a slight alternating flexion of the blade in the direction of the main axis of the aircraft. The presence of backlash is felt with great sensitivity. In the presence of backlash, tighten the ring nut, according to the technique already described in chapter 4p-4s of the propeller assembly.



Fig. 8.1

⚠ WARNING

The presence of significant backlash in the fixing ring nut can be very harmful to the integrity of the propeller. In particular, under particular clearance conditions and elastic constants of the system, resonance oscillations can be triggered which can cause cracks and subsequent fatigue failures of some components.

5. Check for any ligatures and tightening bolts of the propeller to the flange
6. Check the spinner fixing bolts
7. Check the collector and current transmission brushes
8. Check the blades: if you see any changes in the surface such as roughness, cracks, bubbling or discoloration, **DO NOT operate your propeller**

9.2 HUB AND METAL SHANKS SCHEDULED MAINTENANCE

 **WARNING**

Checking and tightening blades, after installation, at: 5 hours, 25 hours and 50 hours

 **WARNING**

Every 100 hours/ 1 year (whichever occurs first) , inspection and mandatory maintenance according to the following procedure

The 100 hours inspection may be performed by the Manufacturer or by an Authorized maintenance workshop.

 **CAUTION**

Before any intervention, make sure that the engine is safe from accidental starting.

- a) Remove the spinner from the propeller and check for cracks. Cracks on the spinner are not allowed.
- b) Check the hub for cracks or oxidation areas. In the presence of oxidation, clean the oxide with fine sandpaper and protect the surface. The presence of cracks is not allowed. If in doubt, examine the presence of cracks with the penetrating ink technique and contact the Manufacturer immediately
- c) Remove each blade in sequence from its seat, by performing the reverse operations in the seat described in par 4l-4q. In particular: unscrew the ring nut with the appropriate key; with a slight oscillating movement, remove the blade from its seat
- d) Open the two roller bearings of the blade, clean the grease and examine the condition of the components. The bearing washers must be free from corrosion and cracks. In case of cracks, contact the Manufacturer. Broken rollers, roughness and teeth on the bearings are not allowed. In case of one of these defects, contact the Manufacturer. In case of corrosion, wash with WD40 or equivalent, using a brass wire metal brush



Fig. 8.2



Fig. 8.3

If corrosion has affected the washers, the bearings must be changed. This corrosion of the bearings can only take place if water has entered the hub, due to rain, washing with a lance at direct pressure towards the hub or due to condensation due to environmental weather conditions. Prevent water from entering the hub by suitable protections. If corrosion is detected, this maintenance must be repeated at closer intervals in order to protect the parts with lubricant. The recommended grease is: White lithium grease.

Example: Lucas oil 10533 white lithium grease, Starbrite 026214 white lithium grease, CFG Grasso bianco al litio.

- e) Thoroughly clean the anchor flange and the base of the shank. Check the entire circumference, near the connecting radius, under optimal lighting, for cracks in the indicated area. In case of cracks, contact the manufacturer immediately

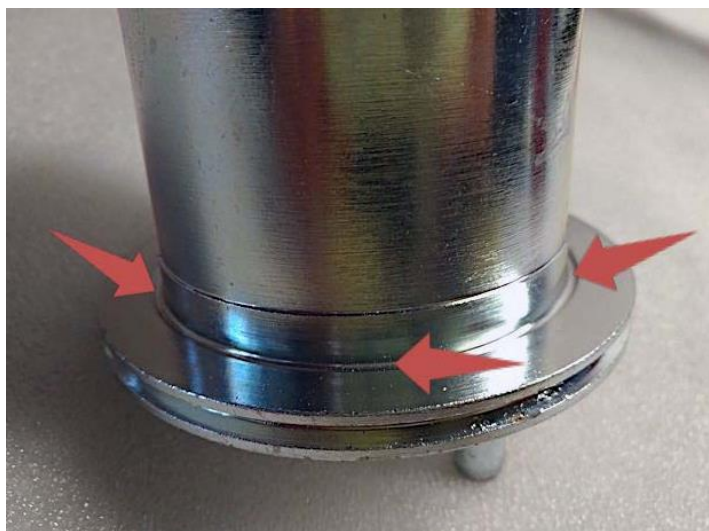

Fig. 8.4

- f) Grease the two bearings with grease with high adhesion to the steel (White lithium grease), reposition the bearings and reassemble the blade in its seat as described in par 4l-4q



Fig. 8.5



Fig.8.6

⚠ CAUTION

Note: the blade shank cannot be disassembled but is irreversibly cemented or structurally inserted during blade construction.

g) Reassemble the spinner as described in the CHAP. 5

9.3 BLADES SCHEDULED MAINTENANCE

Sensenich blades, check:

3B0R5 Installation Instructions rev-C-2018-10-02

Chapter:

- INSTRUCTIONS FOR CONTINUED AIRWORTHINESS
- INSPECTIONS
- REPAIRS

only for what concerns the blades

Warp-Drive blades, check:

Warp-Drive-Propellers_090-01-21_Manual_HPL_3-Blade

Chapter:

- REPAIRS
- GENERAL INSPECTION
- DISSEMBLY INSPECTION

only for what concerns the blades

Whirlwind blades, check:

GA-RW3B-Installation-Guide For Rotax 912/914 Engines Rev7: 05/202

Chapter:

- INSPECTION
- Continued Airworthiness Requirements

only for what concerns the blades

Fp-propeller blades:

Every 100 hours/ 1 year (whichever occurs first)

Visual inspection for deformation, wear, and cracks. Inspect the entire length of each blade looking for any leading-edge damage, fractures or finish wear. If major repairs are necessary, return the propeller to the Fp-propeller factory for inspection and repair/replacement.

10. SPECIAL CHECKS

WARNING

In order to ensure maximum flight safety, it is required to carry out, in the long term, the control of the cracks on the hub (par 8b) and on the blade shank (par 8e) by means of penetrating ink and magnetoscopy techniques respectively.

These techniques are non-destructive and, to give reliable result, they must be carried out by skilled people.

These checks must be carried out:

- When purchasing a used aircraft.
- After an accident in which one or more blades were broken
- Every 500 flight hours.

If the technician who can perform these special checks is not in the area, contact the FP-propeller, who will carry out the tests and issue the relative certificate. For this purpose, the propeller must be dismantled from the aircraft and sent to the company.

11. PARTS TIME BETWEEN OVERHAUL (TBO)

- HUB: 2000 hours/6 years (whichever occurs first)
- Blades manufactured by Fp-propeller: 2000 hours/6 years (whichever occurs first)
- Blades from other manufacturer: the warranty provided by the manufacturer will be applied

Upon expiry of the TBO, the propeller must be sent to FP-Propeller, which will establish a possible further period of use based on the state of efficiency / wear that will be found on the interested parties. Any repairs will not in any case be useful to reset or reduce the service age of the affected component.

12. IDENTIFICATION

Fp-propeller products are identified by a combination of letters and numbers:

Example: **VPH6-TE-R75DN**

Where:

Manufacturer: **V** denotes “FP-PROPELLER”

Product: **P** denotes “Variable pitch propeller”

Dimensions: **H6** or **H3** denotes “hub size”

Configuration: **T** denotes “three-blade propeller”, **B** denotes “two-blade propeller”

Type: **H** denotes “Hydraulic hub”, **E** denotes “Electric hub”

Blades type: final parts of the code **-R75DN** denotes “blades type”

Hub code is labeled on the hub, blades code is labeled on the rear of each blade, near the shank.

Same code and serial numbers are written on the provided PROPELLER LOGBOOK.

13. ANNEX A

Annex A shows the possible combinations HUB/blades and the technical data.

HUB VPH3-BE

Propeller code [VPH3-BE-HHS]

- **Blade type:** FP-propeller model HHS
- **Propeller diameter:** 1750 mm
- **Weight :** 8,40 kg
- **Moment of inertia:** 3.700 kg*cm²

HUB VPH3-TE

Propeller code [VPH3-TE-HHS]

- **Blade type:** FP-propeller model HHS
- **Propeller diameter:** 1750 mm
- **Weight :** 11 kg
- **Moment of inertia:** 6.800 kg*cm²

Propeller code [VPH3-TE-MS]

- **Blade type:** FP-propeller model MS
- **Propeller diameter:** 1780 mm
- **Weight :** 9.58 kg
- **Moment of inertia:** 5.600 kg*cm²

Propeller code [VPH3-TE-R68CN]

- **Blade type:** Sensenich model R68CN
- **Propeller diameter:** 1780 mm
- **Weight :** 9.2 kg

- **Moment of inertia:** 4.700 kg*cm²

HUB VPH5-TE

Propeller code [VPH5-TE-WD70C]

- **Blade type:** Warp Drive model 70C
- **Propeller diameter:** 1780 mm
- **Weight :** 8.4 kg
- **Moment of inertia:** 4.900 kg*cm²

Propeller code [VPH5-TE-GARV]

- **Blade type:** Whirlwind model GA-RW3B
- **Propeller diameter:** 1780 mm
- **Weight :** 8.4 kg
- **Moment of inertia:** 4.900 kg*cm²

HUB VPH6-TE

Propeller code [VPH6-TE-L69EN]

- **Blade type:** Sensenich model L69EN
- **Propeller diameter:** 1780 mm
- **Weight :** 10.92 kg
- **Moment of inertia:** 5.200 kg*cm²

Propeller code [VPH6-TE-R70EN]

- **Blade type:** Sensenich model R70EN
- **Propeller diameter:** 1780 mm
- **Weight :** 10.92 kg
- **Moment of inertia:** 5.200 kg*cm²

Propeller code [VPH6-TE-R75DN]

- **Blade type:** Sensenich model R75DN
- **Propeller diameter:** 1900 mm
- **Weight :** 11.2 kg
- **Moment of inertia:** 7.300 kg*cm²

CONDITIONS FOR SALE

1- SALES are made under the general conditions of the selling Company. They can not be altered unless by the selling Company and by written document. All sales are intended as to be "subjected to approval by the seller". Within 15 days fro receipt of the purchase order, the seller will send wrtten confirmation.

Fp-propeller Srl reserves the right to refuse the order.

2- ESTIMATES AND TECHNICAL DATA. Estimates by the seller are not binding. Illustrations, measurements, weights and all the characteristic data resulting from catalogs must be considered as approximate values. They are communicated by the seller for information only and without responsibility. The seller reserves the right to make changes to its products without prior notice and without obligation to apply such changes retroactively.

3- DELIVERY. The sold material will be delivered as soon as possible, subject to the commitments outstanding and to the possibility of production by the factory. The delivery time is therefore only indicative term. It does not constitute an essential condition of the contract. .The delivery term is adequately extended by effect of events independent from the will of the supplying company. In any case, the customer may not claim damages or other related to late delivery.

4- TRANSPORT. The sale of goods is carried out "ex works." It travels under full risk and peril of the customer. The eventual loss or damage of the goods shall not give rise to claims to the seller for damages. The transport insurance will only be made if requested by the customer and at his charge; The request of insurance must be made explicit in the order.

5 PRICES AND TERMS OF PAYMENT. FP-propeller Srl. may modify its prices at any time. The payments of the supply must be made within the period reported in the order confirmation, signed for acceptance by the customeer. For any dispute concerning the material supplied or for any other divergence the Buyer may not suspend payments. Failure to pay the agreed price even for only one part, the non-compliance with contractual obligations and failure by the buyer of one of the above conditions, entitle FP-propeller Srl to obtain immediate completion of all obligations assumed by the buyer, or termination of the contract being worth this as a termination clause about. Delay in paying in the agreed deadlines by the Purchaser, entitles the supplier to apply the monthly interest at the reference rate EURIBOR + 5 points.

6- TERMINATION. In case of contract termination due to breach, the payments in advance alreay done will remain acquired by the seller Company as indemnity, except the eventual more damage. In any case it will be due to the seller, as a penalty, a sum equal to 15% of the value of sold material, always subject to the most damage.

7-RESERVE OF PROPERTY. The seller, according to Article 1523 Cod. Civ., keeps the property of the material sold until the full pyment of the agreed price. Therefore, the object of the supply will pass to the Buyer property only with the completion of the amount due, while assuming the same risks from the time of delivery. Under request of the seller and in charge to the buyer, it will be provided to all the formalities required by art. 15234 Cod .. Civ. for which the buyer agrees the same at any time.

8-WARRANTY. Products of the FP-PROPELLER S.R.L. They must be installed, maintained and used as specified in the instruction manual provided. Failure to follow these instructions cancels, erases all the responsibility for FP-propeller Srl. The propeller user always flies under his entire responsibility. The Company FP-propeller Srl guarantees its products for twelve (12) months after delivery. The warranty covers free repair or replacement of parts that presented established defects in materials, construction, or workmanship; it takes place after examining and finding faults and their causes, to be made by the seller and at its workshops or in those which are authorized to do so. The costs of any inspections, granted by the seller, for transportation to repair or replace, as well as the hand work for the installation thereof shall on charge of the buyer. The warranty is not transferable to third sub-buyers and ceases if products are used in a manner

inconsistent with the instructions of the house; if they are dismantled, repaired, modified, also in part, without the permission and the control of the seller or its delegates. All parts subjected to wear and tear during the use are not covered by the warranty.. For parts not manufactured by the seller, the warranty is supplied directly from the manufacturer of the part itself. In any case, it is limited to the warranty limits granted by that manufacturer. Furthermore, the use of the propellers for the flight must be made by applying strictly the instructions and the control procedures, to ensure maximum safety. **Therefore, under no circumstances, the buyer may demand compensation for any damages due to the use of the propeller.**

9- COMPLAINTS. Any complaint must be received by the supplier within eight days of receipt of goods by the customer. Claims for breakages or missing parts compared to the delivery document should be communicated to the carrier upon receipt. The complaint does not release the buyer from the obligation to withdraw other regularly ordered goods ready for delivery or allow him to reduce or suspend the payments agreed

10- JURISDICTION for all disputes related to this contract, both parties Buyer and Supply recognize the competence of FERRARA COURT